



MODEL MSD

MOTION SENSING CONTROL

The **Model MSD** is comprised of two different components, a control unit and a speed sensor. The **MSD-800** control unit is a programmable controller that has two set points permitting it to indicate two under-speed points, or two over-speed points, or one of each. The control unit acts as a digital tachometer that constantly displays the actual rotary speed of the equipment being monitored. The control unit is installed remotely in a control panel where it is free from dust, dirt and vibration. This allows the operator to monitor equipment from one central location.



The speed sensor, which is installed directly to the shaft of the rotating equipment being monitored, is enclosed in a rugged cast aluminum housing designed to withstand harsh environments. The enclosure is weatherproof, dust-tight and meets NEMA Type 3S, 4, 4X classifications. For hazardous environments, explosion proof sensors are available that meet NEMA Type 7, Class I Groups C and D and NEMA Type 9, Class II, Groups F and G classifications.

RELIABLE SPEED SENSOR

- Rugged cast aluminum housing
- Weatherproof & dust tight enclosure
- Explosion-proof models available
- Installs directly onto drive shaft & generates pulses

The **Model MSD-800** series motion sensing controls offer affordable and reliable protection of indoor and outdoor rotating equipment such as screw conveyors, belt conveyor pulleys, rotary feeders and bucket elevators from costly damage by continuously monitoring rotary speed. The Model MSD alerts the operator of a change in speed by sending a signal to the control unit which can be set to sound an alarm and/or shutdown the equipment completely. By monitoring speed you can greatly reduce system and equipment downtime by fixing malfunctions such as broken drive gears or belts, over-worked motors, belt overload and other problems before serious damage occurs.

OPERATION

The Model MSD-1 sensor detects motion by means of a precision metal disc with slots on its periphery generating electronic pulses as the disc rotates past an infra-red light source. These pulses are transmitted to the MSD-800 control unit where the signal is analyzed and the relays are activated or deactivated at preset signal speeds. The MSD-800 control unit is designed to permit two signal set points. Field adjustment of the signal set points is easily accomplished through the buttons on the face of the control unit.

PROGRAMMABLE CONTROL UNIT WITH TWO SET POINTS AND DIGITAL TACHOMETER

- Indicates two under-speed points or two over-speed points, or one of each
- Field adjustable to desired speed set points
- Panel Mount for easy access in a location free from dust, dirt and vibration
- LCD Display shows shaft RPM
- 100-240 VAC Power input, 24 VDC available



MODEL MSD

MOTION SENSING CONTROL

INSTALLATION AND WIRING:

Mount the MSD-1 or MSD-1X sensor in any position on a smooth, flat surface using 1/4" mounting bolts and lock washers. If vibration is extreme, use dowels in two mounting holes and use bolts in the other two mounting holes. The sensor shaft must be in line or parallel with the drive shaft.

Wiring and conduit installation is done by the customer, including the use of appropriate conduit fittings and seals rated for the installation environment.

Use two conductor shielded cable (such as our MSD-14 or Belden 8760 equivalent) to connect the MSD-800 control unit with the MSD-1 sensor. A maximum of 4,000 feet of cable can be used between the control unit and sensor. The control unit should be mounted prior to final wiring. With the mounting bracket removed, slide the control unit into a 1/16 DIN (45 mm x 45 mm) cutout. Then slide the mounting bracket onto the rear of the unit and secure with the attached screws.

The control unit contains three failsafe output circuits: one SPST relay (Output 1, normally open), one Transistor (Output 1, NPN), and one SPDT relay (Output 2). Output relays/transistor are energized under normal conditions and de-energize under alarm conditions. The relays/transistor de-energize (alarm) in the event of power failure, during a start-up delay, and during a reset event. NOTE: Relay contacts are labeled in reference to their de-energized (alarm) state.

The MSD-800 control unit comes fully programmed from the factory, ready for use with the MSD-1 sensor. The primary menu settings that may need to be changed in the field are the Tachometer Output Mode (Over-speed/Underspeed configuration) and the Startup Delay.

MSD-1 (or MSD-1X) SENSOR

- Power Input:** 12 VDC from the control unit
- Output:** 12 VDC NPN square wave to control unit
- Ambient Temperature:** 14°F to 131°F (-10°C to 55°C)
- Max. Operating Temperature:** T6: 185°F (85°C) "X" units only
- Maximum Speed Limit:** 1000 RPM
- Shaft Load:** 125 lbs. radial, 100 lbs. end thrust
- Rotation:** Clockwise or Counter-clockwise
- Drive Torque:** 1 inch-pound
- Shaft:** 5/8" dia. x 1-1/4" long stainless steel
- Enclosure:** 319 cast aluminum; NEMA Type 3S, 4, 4X compliant (MSD-1)
- Optional:** Type 7 Class I Groups C and D, and Type 9 Class II Groups F and G compliant (MSD-1X)
- Bearings:** Permanently lubricated and sealed for life ball bearings Operating Range: 0-1000 RPM
- Signal Accuracy:** +/- 1 RPM

MSD INTERIOR VIEW (Cover Removed)

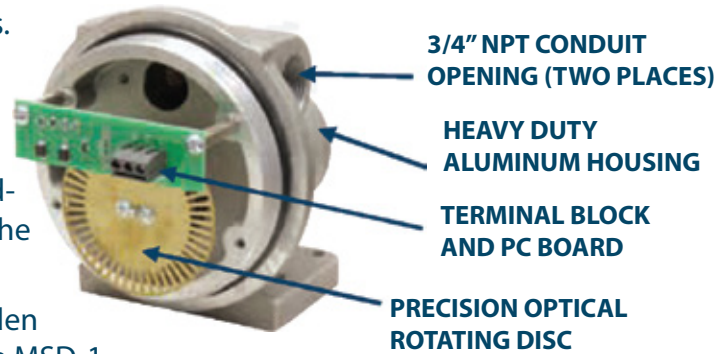

MSD-800 Control Unit:

- Power Input:** 100 - 240 VAC, 50/60 Hz
- Optional:** 24 VDC (MSD-800-24)
- Power Consumption:** Less than 10 VA (AC input), less than 5 W (DC input) Output Power to Sensor: 12 VDC
- Signal Input From Sensor:** 12 VDC square-wave, NPN or PNP (field programmable)
- Output 1:** SPST Relay: rated 5 amps resistive at a maximum of 250 VAC;
- Transistor:** NPN open collector. When 100mA/30 VDC, residual voltage = 1.5 VDC max.
- Output 2:** SPDT rated 5 amps resistive at 125/250 VAC;
- Ambient Temperature:** 32°F to 122°F (0°C to 50°C)
- Storage Temperature:** -4°F to 149°F (-20° to 65°C)
- Reading Accuracy:** .1 to 1 RPM
- Alarm Set Accuracy:** .001 to 1 RPM
- Mounting:** 1/16 DIN panel mount (45 mm x 45 mm cutout)
- Certifications:** UL, CE

MODEL MSD

MOTION SENSING CONTROL

MODEL MSD control unit

MODEL #	DESCRIPTION	DIGITAL TACHOMETER	SHPG. WT.
MSD-800	CONTROL UNIT: Indicates two under-speed or two over-speed points, or one of each. 110-240 V AC power input.	YES	2.0
MSD-800-24	CONTROL UNIT: Indicates two under-speed or two over-speed points, or one of each. 24 V, DC power input.	YES	2.0

MODEL CMS & MSD - ACCESSORIES

MODEL #	DESCRIPTION	SHPG. WT.
303	Stub Shaft, 5/8" diameter	0.5
304	Flexible Coupling, 5/8" x 5/8"	0.5
305	Coupling Guard	0.5
310	Sensor Mounting Bracket	1.0
311	Bearing Bracket - Small	2.5
312	Bearing Bracket - Medium	6.0
313	Bearing Bracket - Large	10.0
MSD-14	Two conductor shielded cable to connect control unit and sensor (Belden 8760)	0.02

MODEL MSD MOTION SPEED CONTROL - SENSOR

MODEL #	DESCRIPTION	SHPG. WT.
MSD-1	SPEED SENSOR: The enclosure is weatherproof, dust-tight and meets NEMA Type 3S, 4, 4X classifications.	7.0
MSD-1X	SPEED SENSOR: The enclosure is explosion proof for hazard-ous environments and meets NEMA Type 7, Class I, Groups C & D and NEMA Type 9, Class II, Groups F & G classifications.	7.0

Epoxy coating option: add "E" to end of model number.

MSD BEARING BRACKETS AND SHIM PLATES

PART #	SHAFT DIA.	A	B	C	D
311	1-7/16"	1-1/4" to 2"	1-7/8 to 2-1/8"	3-1/8"	1-1/8"
312	1-15/16" to 2-7/16"	1-1/2" to 2-9/16"	2-1/4" to 3"	3-3/4"	1-5/8"
313	2-15/16" to 3-15/16"	3" to 3-3/4"	3-1/8" to 4-1/8"	4-1/2"	2-3/16"

Mounting Bracket: Part number 310 will fit Part Numbers 311, 312 or 313

CONTROL UNIT DIMENSIONS

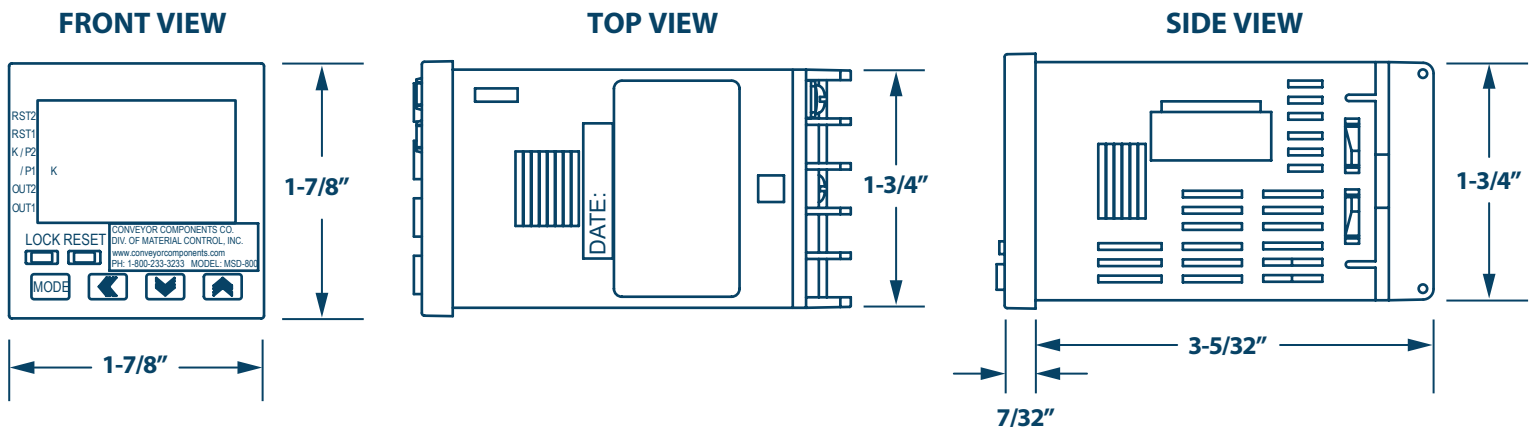

AIRMATIC[®] INC

...HELPING PRODUCERS EXCEL![®]

AIRMATIC[®] INC founded in 1944, is a woman-owned Industrial Distributor, with installation and maintenance capabilities, offering equipment, machinery, and shop supplies to the Industrial, Construction, Utility, Government, and Commercial Markets. Our products and services are sold through three business units:

The **MATERIALS MANAGEMENT GROUP** provides products and services to industries that convey, store, transport, and process powders and bulk solids from aggregates, cement, and chemicals to foods, grains, metals, power generation, and waste water treatment applications;

The **SERVICE GROUP** provides fabrication, installation, and maintenance services to improve bulk materials handling efficiency; mechanical clean-out services for silos and hoppers to eliminate material flow problems; and shop repair/rebuilding and modifications services of products sold by the Company. Our Customers tell us that by choosing AIRMATIC to solve their problems, they gain increased productivity, decreased costs, and a safer, cleaner work environment.

The **TOOL GROUP** provides power tools, personal protective equipment, materials-handling equipment, shop equipment and MRO supplies used for production, fabrication, assembly, metal removal, maintenance, and storage in manufacturing, construction, utility, and commercial applications.

800.332.9770 *Toll Free*
+1 215.333.5600 *International*



888.964.3866 *Toll Free*
+1 215.331.9770 *International*



www.airmatic.com



infocenter@airmatic.com



284 Three Tun Rd. Malvern PA, 19355

